

# Battery Solutions for eMobility

ELANTAS is a firm believer that mobility in connection with renewable energy is the key for future sustainable mobility and reduction of global emissions. To support the growth of mobility globally we support this market with innovative products which help to operate electric vehicles safely and enable innovative, cost efficient solutions through our products. As a market leader for electrical insulating and protection materials ELANTAS has over 100 years of experience in the industry.

**Wide range of protection and insulation materials** for electric vehicles The ELANTAS product portfolio offers a broad range of protection and electrical insulation materials that can be found in the motor, powertrain, battery and other electronic components of a vehicle. Different chemistries are available to provide the product with the best fitting properties for the application. ELANTAS is also offering customized solutions for specific application needs which are developed together with our customers.

#### **Global Presence for a Global Industry**

Our global team of R&D experts and technical managers are working closely with customer design engineers and technical staff to solve their issues, and are supported by the local ELANTAS application labs in the regions. As a long term supplier to the automotive industry ELANTAS understands the requirements and expectations throughout the entire automotive value chain and is working according to given standards (IATF 16949), and supplies from our manufacturing sites in the region on short lead time.

## Battery Products: Protection and longevity for electric vehicles

The battery systems in electric cars are highly relevant to the success of electromobility.

A vehicle's market price, performance while driving and charging, longevity and sustained range over its lifetime, and safety are just a few factors that the battery essentially determines.

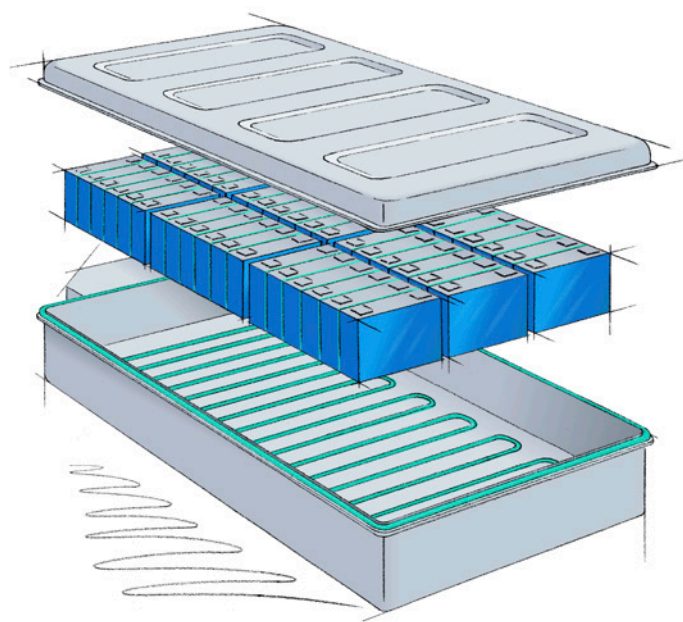

## Coatings

The complexity of battery packs in electronic vehicles involves several electronic or electric elements that require protection by polymeric coatings. ELANTAS is experienced in various chemistries and application methods, for example:

- The printed circuit **boards** of battery management system at the module or pack level are frequently **coated with polymeric resins** of various thicknesses to protect them and guarantee **longevity**.
- Resin coatings are also used on **busbars connecting the modules** in the pack. Here, the coatings ensure **excellent insulation of the conductors** to ensure **safe and long-term** use under high-voltage conditions in today's batteries.

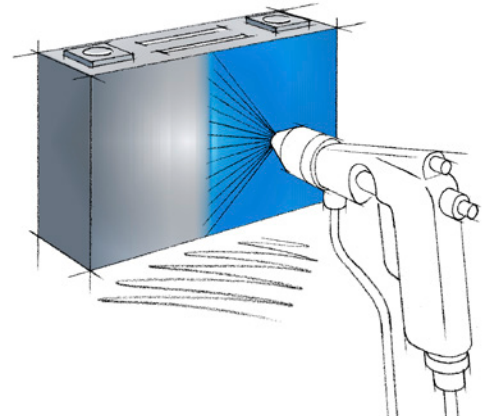

Coatings for Electronics	Chemistry	Special Benefit	Viscosity [mPas]	Typical Temp Range [°C]	Tack Free Time [min]	Curing
Bectron® PL 4122 – 40E	PU-Alkyd	Excellent cost / performance ratio, established for automotive applications by large OEMs	80	-40 to 125	15	16h RT / 30 min 80 °C
Bectron® PT 4700 N	PU-Acrylate	Fast throughput due to UV curing	200	-40 to 125	–	seconds at UV / 2d RT
CONAP® CE 1164	PU	Best combination of properties, highest reliability over long time period	100	-40 to 130	25	24h RT
Bectron® PL 5622-250	EP	Fast throughput due to UV curing Improved chemical resistance	250	-40 to 150	–	seconds at UV / 30 min 90 °C
Bectron® SC 76V1-20	Si	High temperature stability	875	-50 to 200	12	24h RT / 15 min 40 °C

All values are typical values.

## Sealants & Adhesives

The anticipated lifetime of a battery pack is about 15 years. Therefore, the housing and all connection points to the pack need to be securely sealed.

- ELANTAS sealants **protect the valuable interior battery components** from water and dirt, which could harm performance.
- They have been shown to **withstand** stress under **varying weather conditions** and **vibrations**, as simulated in automotive exposure tests.

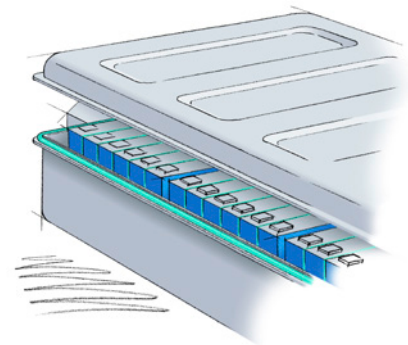

Sealants & Adhesives	Chemistry	Components	Color	Thermal Conductivity [W/mK]	Shore Hardness	Curing	Viscosity [mPas]	Density [g/ml]
Elan-tron® PU79/PH79	PU	2	light gray	1.70	D 50	RT / moderate heat cure	80000	1.80
Bectron® AR 4826 N	PU	1	yellow	0.20	A 67	RT / moisture	Thixotropic Paste	1.1
Bectron® SA70P9-50	Si	1	black	0.27	A 60	RT / moisture	Thixotropic Paste	1.3
Bectron® SA 70L1-30	Si	1	pale yellow	0.2 0	A 30	RT / moisture	Thixotropic	1.06
Elan-glue® EP 5611	EP	1	pale white	0.46	D >90	UV or heat cure	32500	1.63
Elan-glue® AC 1650	Acrylate	1	translucent	0.2 0	D 85	UV cure only	8000 @ D = 20 1/s	1.04

All values are typical values.

## Gap Filler

The electrochemical reactions in battery cells for e-cars are highly dependent on temperature. Therefore it **essential to maintain the battery cells within a healthy temperature window of operation.**

In addition, **minimizing the temperature differences** within the module and pack is **crucial to ensuring longevity.** Unwanted side reactions in local hot spots within the pack decrease cell capacity and result in continuing loss of overall capacity. **Management of the heat flow**, for example with the help of ELANTAS gap fillers of silicone or polyurethane chemistry is therefore critical.

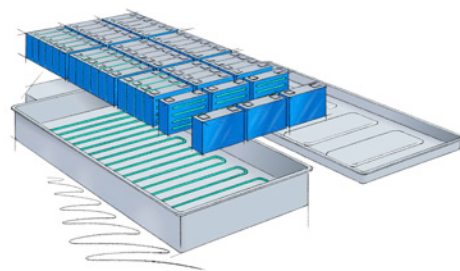

Gap Fillers	Chemistry	Components	Ratio by Weight	Mixed Viscosity [mPas]	Density [g/ml]	Thermal Conductivity [W/mK]	Shore Hardness	Tensile Strength [Mpa]	Elongation [%]	Typical Temp Range (°C)	Curing	UL
ELAN-tim® FS 15 OP 0132 + 0143	Si	2	1:1	100–200	2,90	1,50	OO 60	0,3	90	-50–200	12–24h@RT/ 1h@120 °C	V-0
ELAN-tim® FS 20 OP 0112 + 0123	Si	2	1:1	100–200	2,20	2,00	OO 60	0,2	40	-50–130	12–24h@RT/ 1h@120 °C	V-0
ELAN-tim® FS 26 OP 0012 + 0023	Si	2	1:1	paste	3,00	2,60	OO 60	0,2	45	-50–200	12–24h@RT/ 1h@120 °C	V-0
ELAN-tim® FP 21 AP 0092 + 0103	PU	2	1:1,95	210000	2,78	2,10	A70	0,9	25	-40–100	2h@90 °C/ 48h@RT	V-0,6 mm
ELAN-tim® FP 30 AP 0032 + 0043	PU	2	1:2,18	200000	3,00	3,20	A78	0,2	17	-40–130	2h@90 °C/ 48h@RT	HB/V2

All values are typical values.

Casting & Potting Resins	Chemistry	Components	Ratio by Weight	Mixed Viscosity [mPas]	Density [g/ml]	Thermal Conductivity [W/mK]	Shore Hardness	Tensile Strength [Mpa]	Elongation [%]	Curing	UL
ELAN-tim® CS 26 AV 0012 + 0023	Si	2	1:1	10000	3,00	2,60	A60	1,1	18	12–24h@RT/ 1h@120 °C	V-0
ELAN-tim® CS 15 AV 0032 + 0043	Si	2	1:2,41	4000	2,70	1,50	A50	1,15	75	12–24h@RT/ 1h@120 °C	V-0
ELAN-tim® CU 13 AV 0052 + 0063	PU	2	10:1	5700	1,74	1,30	A90	2,4	17	15h@60 °C	V-0
ELAN-tim® CU 16 DV 0072 + 0083	PU	2	100:8	9000	2,00	1,60	D35	2,5	10	15h@60 °C	V-0
Elan-tron® MC724/W365	EP	2	100:7	10000	2,42	2,10	D90	68	na	24h RT/15 h 60 °C	V-0,6mm
Elan-tron® MC336/W360NF	EP	2	100:7,5	12000	1,88	1,55	D85	51	na	24h RT/15 h 60 °C	V-0

All values are typical values.

## Thermal Adhesives

In eMobility applications, the increasing thermal management challenges require **heat dissipation across bondlines**.

- Adhesives are a proven light-weight, effective bonding solution.
- They must reliably **fulfill fixation** and **provide a path for effective heat transfer**.

Examples for thermal adhesives applications are the fixation of cooling elements or heat sinks to the heat source and the cell to cell fixation. For such applications, ELANTAS products are highly recommended. They are suitable for most substrates and can be machine applied or dispensed manually, if preferred.

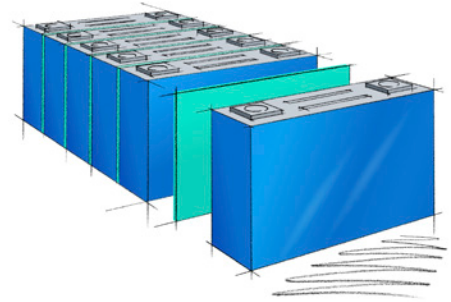

Adhesives	Chemistry	Components	Color	Thermal Conductivity [W/mK]	Shore Hardness	Curing	Viscosity [mPas]	Density [g/ml]	UL
ELAN-tim® AU 17 DM 0012+0023	PU	2		1,70	D 53	15h 60°C	90000	1,40	V-0, 4,5 mm
ELAN-tron® PU79/PH79	PU	2	light gray	1.70	D 50	RT/ moderate heat cure	80000	1,8	
Bectron® EP 5504	EP	2	beige	0,96	D 82	48h@RT	2700	1,70	V-0
ELAN-glue® PK 5550	PU	1	black/grey	0,20	D 60	90 °C / 30 min	29500	1,07	
Bectron® SA 70 L1-30	Si	1	translucent	0,20	A 30	24h@RT	44000	1,06	HB
Bectron® SA 70P9-50	Si	1	black	0,27	A 50	24h/RT	> 100 Pas	1,15	V-0, 3,3 mm
Elan-glue® EP 5611	EP	1	pale white	0,46	D 90	UV/heat	32500	1,63	
Bectron® AR 4826 N	PU	1	translucent	0,20	A 67	24h/RT	Thixotropic	1,10	
Elan-glue® AC 1650	Acrylat	1	translucent	0,20	D 85	UV@RT	14000	1,05	
Bectron® MR 3405	Polyolefin	1	yellow	0,20	A 30	Hot Melt	2100	0,85	
Bectron® MR 3405 FR	Polyolefin	1	black	0,20	A 35	Hot Melt	2000	0,85	V-0

All values are typical values.

## Thermal Grease

In eMobility applications, the increasing thermal management challenges require **heat dissipation across bondlines**.

- Greases are a proven effective heat transfer compound.
- Easy to apply one component non-curing property ensures ideal thermal contact.

Thermal Grease	Chemistry	Type	Mixed Viscosity [Pas]	Density [g/ml]	Thermal Conductivity [W/mK]	Temp Range
ELAN-tim GS12NP0021	Si	1K	paste	1,95	1,20	max 150 °C
ELAN-tim GS12NM0021	Si	1K	30-100	1,85	1,30	max 200 °C
ELAN-tim GS25NH0051	Si	1K	100-1000	2,50	2,50	max 150 °C

All values are typical values.

ELANTAS Europe is part of the ALTANA group and a leading manufacturer of insulating and protecting materials for the electrical and electronics industry. Our portfolio includes wire enamels, impregnating resins and varnishes, flexible electrical insulation materials, casting & potting resins for motors, generators and transformers as well as conformal coatings for protecting PCBs, modules or sensors. In addition, we offer a wide range of adhesives as well as materials for printed electronics.

**ELANTAS Europe GmbH**

Grossmannstr. 105  
20539 Hamburg, Germany  
Tel. +49 40 789460

**ELANTAS Europe S.r.l.**

Strada Antolini, 1  
43044 Collecchio, Italy  
Tel. +39 0521 304777

[www.elantas.com/europe](http://www.elantas.com/europe)  
[info.elantas.europe@altana.com](mailto:info.elantas.europe@altana.com)